

Applications of the RUBY phantom

in high-precision radiotherapy

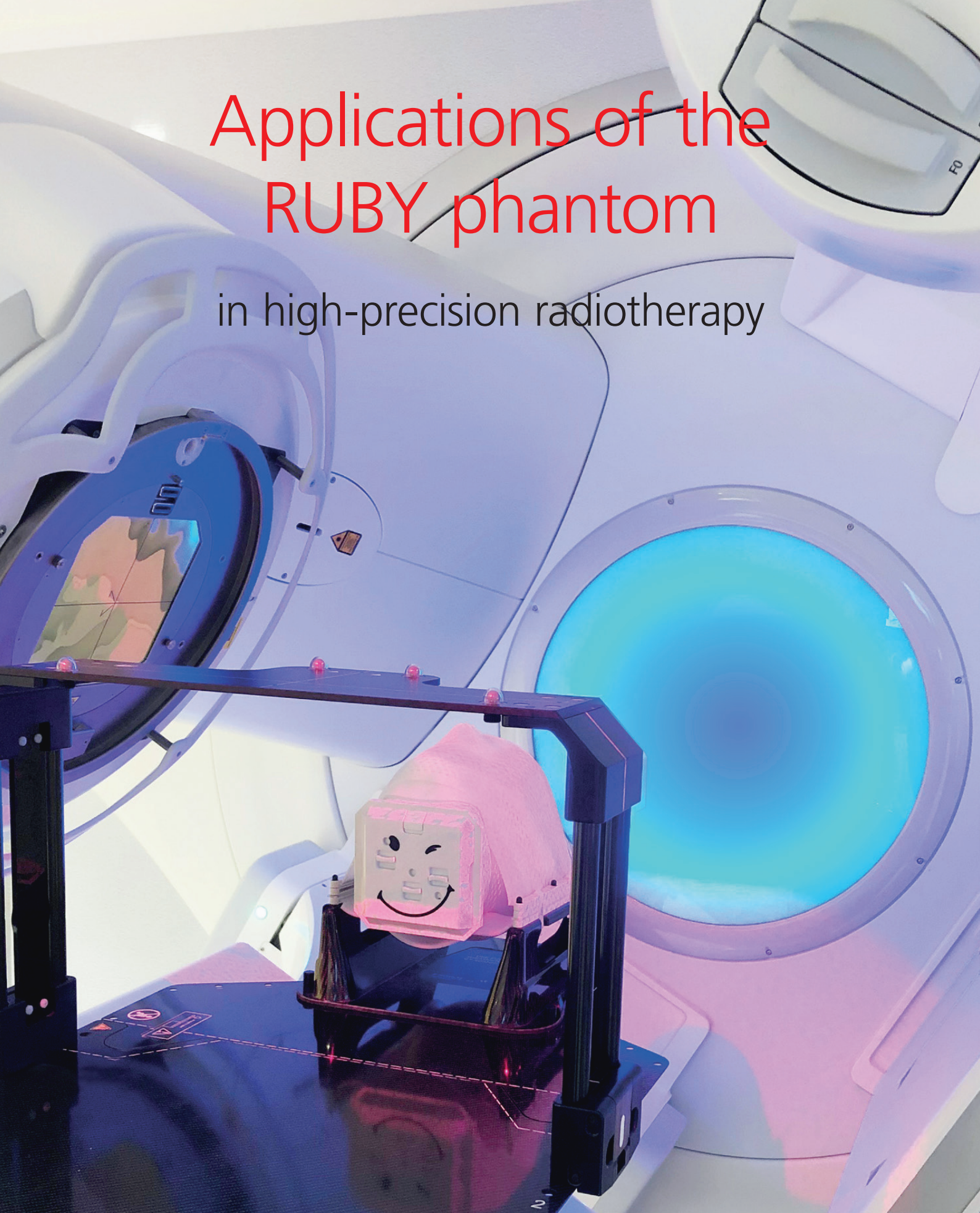

LINAC QA

Accurate patient positioning is an integral part of high-precision radiotherapy that requires the seamless integration between the on-board imaging systems, robotic couches and image registration algorithms. To guarantee the highest possible geometrical

accuracy during each fraction, quality assurance of the whole process must be given high attention. The RUBY Linac QA insert is designed to check of the image-guided patient positioning workflow and, additionally, to perform Winston-Lutz testing.

Patient positioning workflow QA

Preparation

A planning CT of the RUBY Phantom with the Linac QA insert using representative clinical parameters serves as the basis of the test. The plan isocenter can be defined based on a set of six CT markers that indicate the center of the phantom marked also by a set of black line on the phantom's surface.

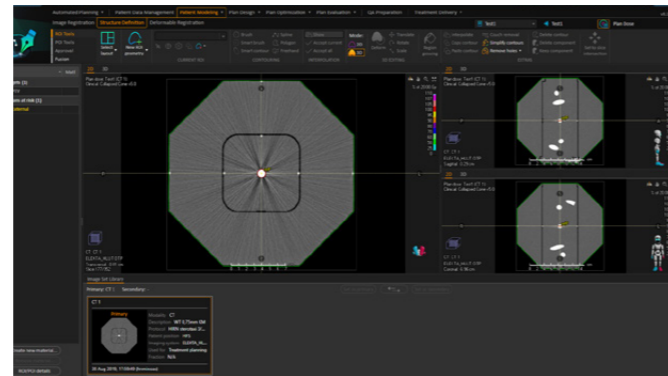

Figure 1: CT dataset of the RUBY with Linac QA insert. The isocenter position is defined based on the 6 CT markers.

RUBY positioning with defined displacement

RUBY is positioned in a defined misaligned position on the couch to perform the test (Figure 2). Two different incorrect positioning options are possible: the grey line enables a defined translational displacement in all three directions; the red line,

in combination with the RUBY tilting base, enables a defined translational displacement and additionally a defined rotation of the phantom.



Figure 2: Left: RUBY aligned using the grey line with translational misalignment. Center and right: Combination of the tilting base and alignment according to the red line for translational and rotational misalignment.

CBCT imaging

The patient positioning workflow based on CBCT can be performed using the clinically used parameters with the aim to detect the misalignment and to compensate this by automatic couch correction. Optimal image registration of the CBCT data set and the reference data set is achieved by the four bone

structures. The test is successfully passed if the black line on the phantom's surface coincides with the room lasers after the couch movement. Displacement errors determined by the system can be compared with the defined values given in the specifications and recorded with Track-It.

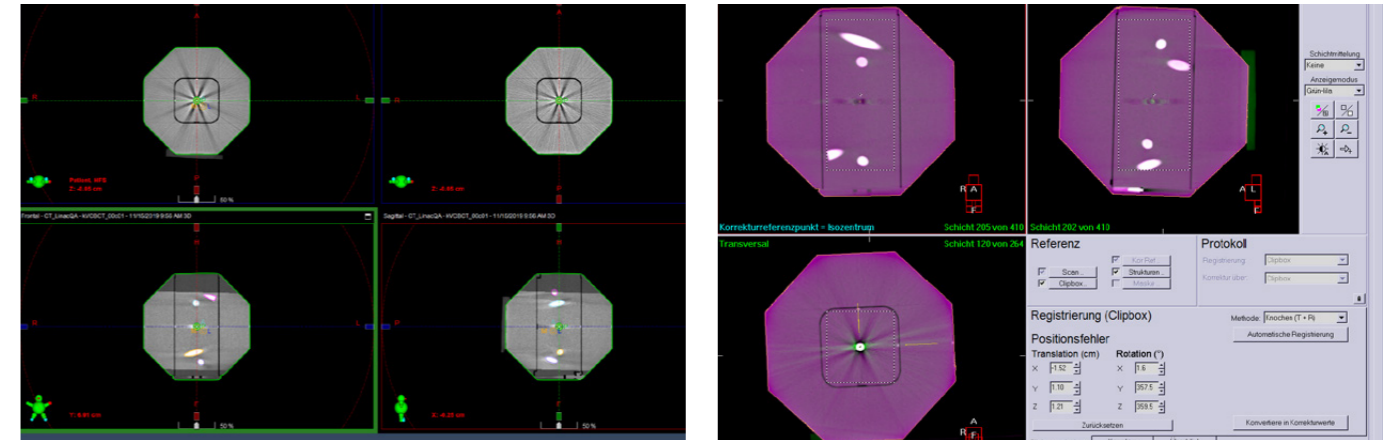

Figure 3: Left: Varian CBCT workflow, right: Elekta XVI CBCT workflow

MV / kV planar imaging

The bone structures allow high visibility in planar images (kV and MV) as shown in Figure 4. This enables manual registration of the portal images to the reference DRR, as well as automatic

registration via software. The displacement values determined by the system can be compared with the values given in the specifications and can be recorded using Track-It.

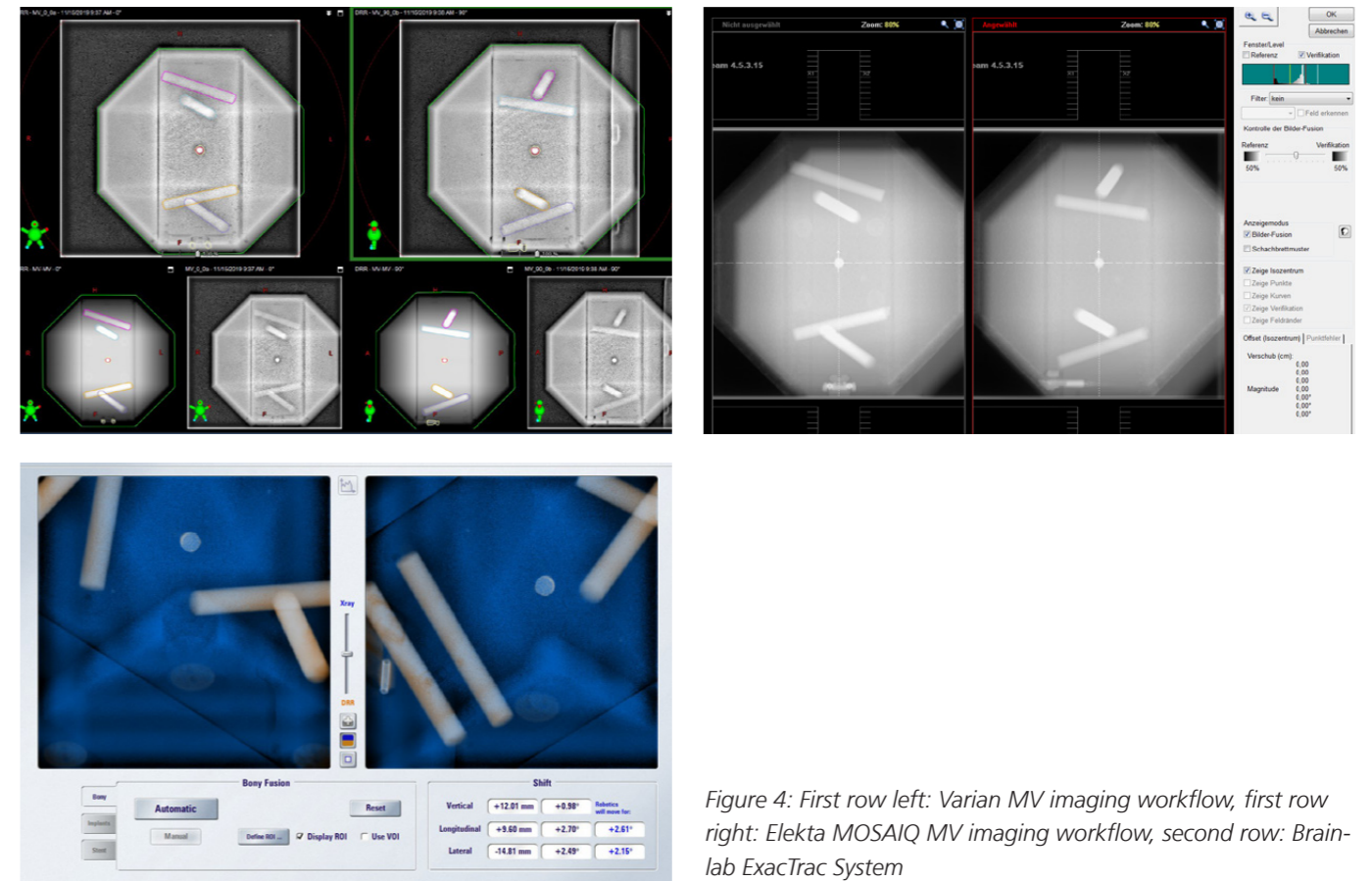
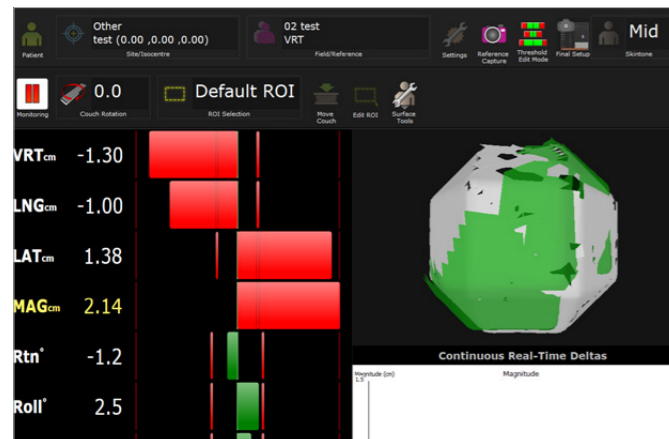

Figure 4: First row left: Varian MV imaging workflow, first row right: Elekta MOSAIQ MV imaging workflow, second row: Brainlab ExacTrac System

SGRT compatibility

The surface of the RUBY phantom is compatible with the Vision-RT and C-RAD surface guided systems. As shown in Figure 5, a misalignment of the phantom can be detected by both



systems. The displacement values determined by the system can be compared with the values given in the specifications and can be recorded using Track-It.

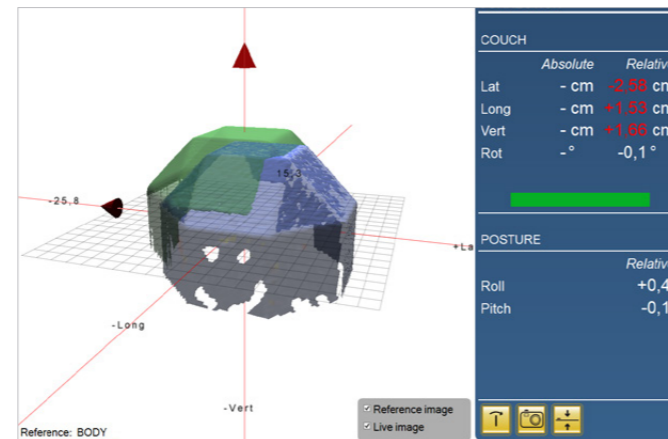

Figure 5: Left: Vision-RT software Right: C-RAD software

Track-It compatibility

The Track-It protocol, e.g. for the daily check, can be easily extended by the misalignment values. Each time the check is performed, the values determined by the system are added to the Track-It protocol. In the case where the check is carried out on a daily basis, a trend can be generated to report on the accuracy of the patient's localization and repositioning system.

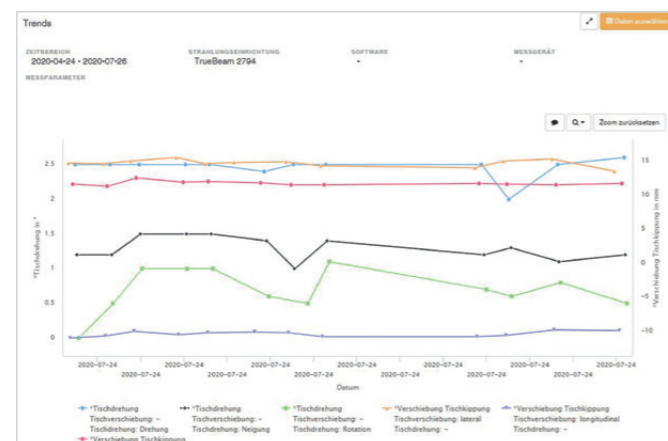

Figure 6: Trend analysis of displacement values for translational and rotational misalignments within the Track-It software environment.

Winston-Lutz testing

The verification of the isocenter positions of the multiple systems in the treatment room, including the beamline, CBCT imaging unit, external kV imaging system, surface detection system and laser positioning system is an integral part of the entire quality assurance process. A ceramic ball at the center of the RUBY Linac QA insert is intended to enable Winston-Lutz testing with RUBY.

The integration of the sphere into the Linac QA insert containing the four bone cylinders allows a variety of initial positions for the

Winston-Lutz test. The RUBY phantom can be aligned according to the laser system using the black lines. In addition, the RUBY phantom may also be positioned on the couch using the CBCT imaging as shown in Figure 3 or the planar kV images as shown in Figure 4. Thus, the RUBY phantom can be either positioned in the origin of the laser system or in the origin of the imaging's coordinate system. The acquired MV images can be evaluated using IsoCheckEPID.

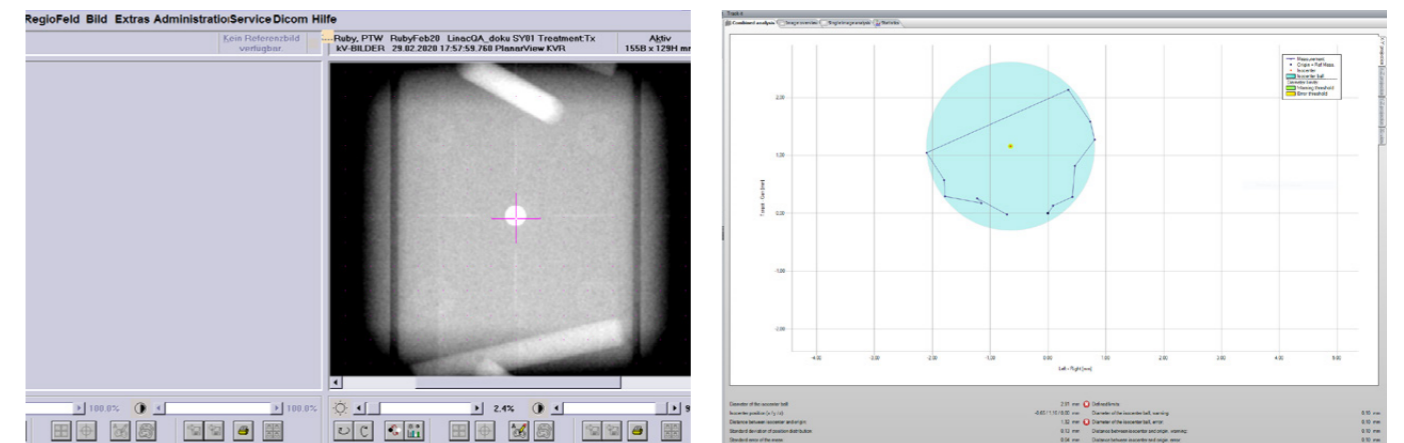

Figure 7: Left: RUBY positioning using planar kV images. Right: Winston-Lutz Test analysis using IsoCheckEPID software.

Patient QA

The RUBY Patient QA inserts for detector and radiochromic film allow for fast point and two-dimensional dose verification of treatment plans. The design of the RUBY phantom also allows

for irradiation from any beam angle without re-positioning, hence enabling the verification of treatment plans with non-coplanar fields (with couch rotation).

Detector positioning

The Patient QA insert is compatible with the following PTW detectors:

- ▶ Semiflex 0.125 (T31010)
- ▶ Semiflex 3D (T31021)
- ▶ PinPoint 3D (T31022)
- ▶ microDiamond (T60019)
- ▶ microSilicon (T60023)

The exact positioning of the detector in the center of the phantom can be realized with the help of the corresponding detector holder that can be screwed into the insert. After the insertion of the detector, its reference point corresponds exactly to the position of the CT markers.



Figure 8: Detector holders ensure the exact positioning of the detector at the center of the phantom and are compatible with a variety of PTW detectors.

Plan verification

For treatment plan verification, a planning CT of the phantom with patient QA insert must be prepared once. For this purpose, the detector insert can be filled with a homogeneous plug provided to avoid artifacts caused by inserted detectors. The CT

data set can be added to the phantom library of the TPS and used thereafter for all treatment plan verifications. Based on the six CT markers, the isocenter position can be easily and accurately defined and the dose value at the isocenter can be extracted.

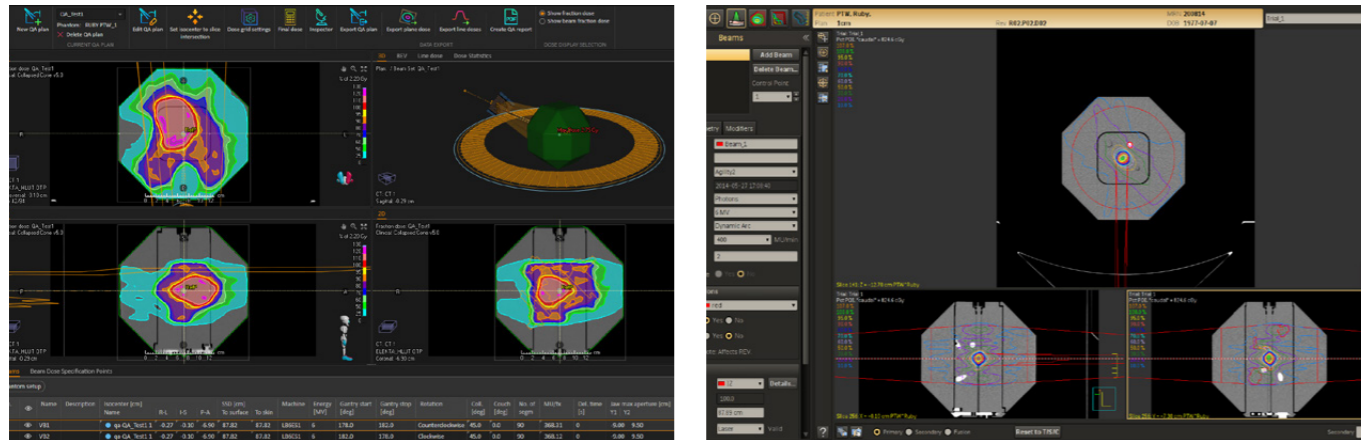

Figure 9: Treatment plan calculated on CT dataset of Patient QA detector insert.

Plan verification with radiochromic film

The Patient QA insert for radiochromic film allows the use of a 17 cm x 9 cm sized radiochromic film. The design of the RUBY phantom permits the film to be positioned at different planes. A

marking plate is used to mark the film relative to the CT markers in the phantom.

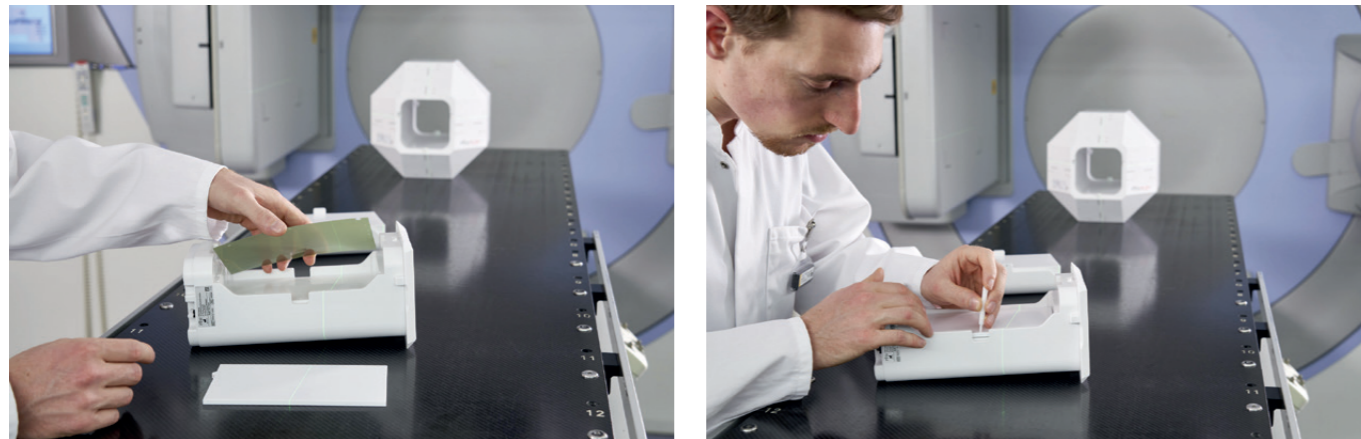

Figure 10: Patient QA film insert allows the use of a 17 cm x 9 cm sized radiochromic film. A marking plate is used to mark the film relative to the CT markers in the phantom.

System QA

End-to-end testing

The RUBY Phantom combined with the System QA insert enables a comprehensive end-to-end testing. The insert contains tissue equivalent materials of different densities (lung, brain and bone), defined structures with specific volumes, MRI visible structures, as well as the flexibility to position a detector at the center of the phantom. The center of the phantom is marked

by 2 mm cylindrical bone equivalent CT markers. This permits a comprehensive end-to-end testing without changing phantom components allowing the highest geometrical precision. In the following, the various steps of the end-to-end testing with RUBY are presented.

Planning CT

A Planning CT with the clinically used parameters can be performed with the RUBY phantom and System QA insert. In order to avoid artifacts caused by the detector, the detector cavity

should be filled with a homogeneous plug. The electron densities of the lung, brain and bone tissue equivalent structures are specified in the datasheet.



Figure 11: Left: Planning CT of RUBY. The detector cavity is filled with a homogenous plug. Right: CT dataset of the System QA insert.

MRI

The MRI visible structures enable MRI visibility in T1 and T2 sequences. Three cylindrical structures with different diameters of 25 mm, 15 mm and 10 mm are visible.

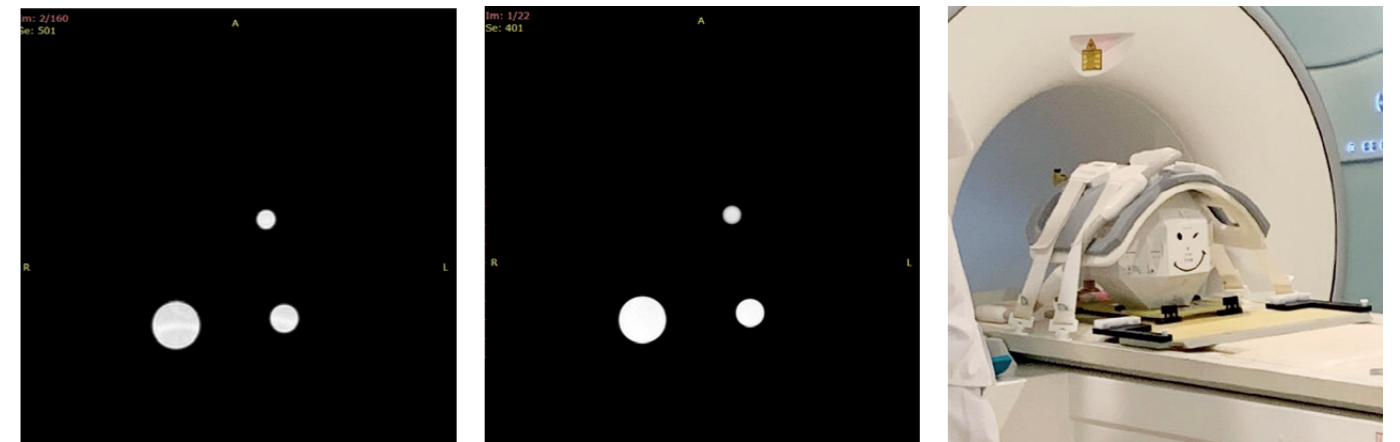

Figure 12: Left: T1 sequence, Center: T2 sequence, Right: RUBY at 3 T MRI.

CT / MRI image registration

Based on the CT data set and the MRI data set, the image registration process can be evaluated in the TPS. Figure 13 shows the registrations performed with different TPS.

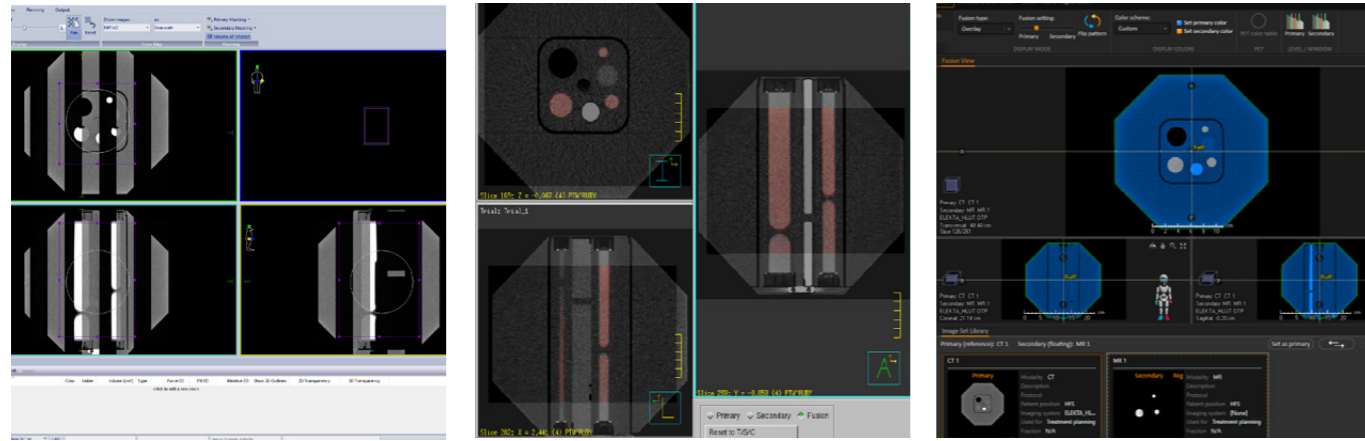

Figure 13: The check of CT / MRI image registration algorithm using the System QA insert

ROI volume calculation

The volume of the lung, brain and bone tissue equivalent material structures are specified in the datasheet. This can be used to check the volume calculation of the TPS and the different ROI contouring methods.

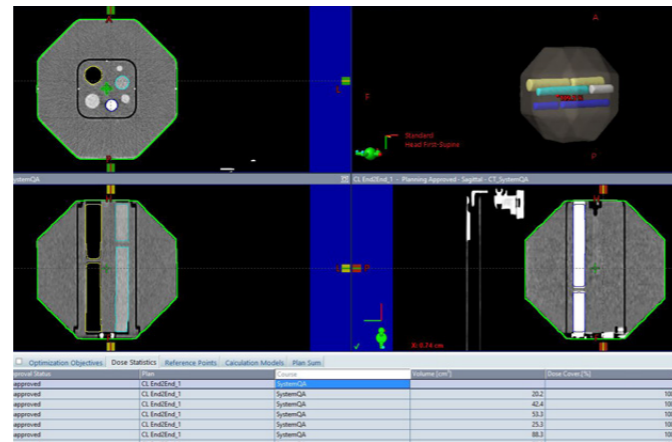

Figure 14: Lung, brain and bone tissue equivalent structures are contoured and the volume are calculated by the TPS.

Treatment planning

Treatment plans from original patient datasets can be re-calculated on the RUBY CT dataset or representative treatment plans can be optimized on the CT dataset. The position of the

isocenter can be defined using the six CT markers. The dose value at the isocenter position is recorded for comparison with the detector measurement in the further procedure.

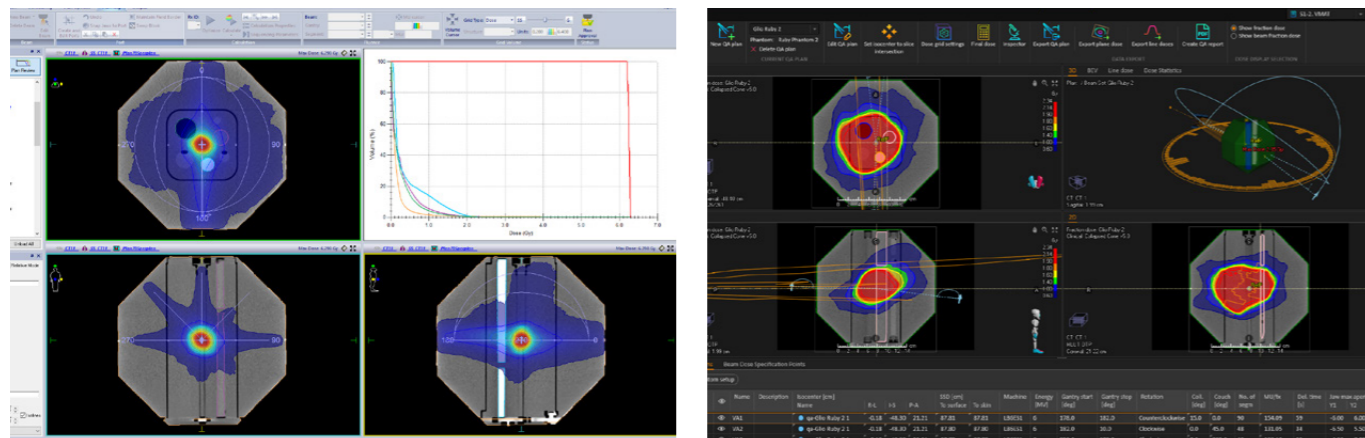

Figure 15: Treatment plans calculated on the CT dataset of the RUBY with System QA insert

Patient positioning workflow

The System QA insert enables the integration of the patient positioning workflows in the End2End test chain. The insert is visible in CBCT imaging and additionally, the RUBY is also SGRT compatible.

Therefore, the patient positioning workflow, either IGRT or SGRT based, can be checked as part of the End2End testing chain.

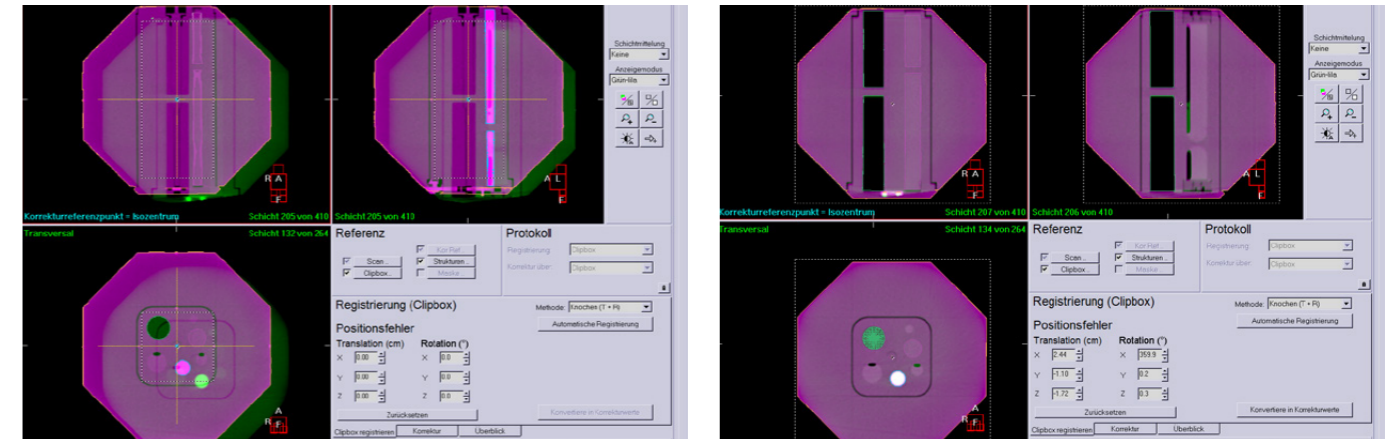

Figure 16: CBCT image registration of RUBY with the System QA insert. Left: Before image registration. Right: After Image registration

Dose measurement

The treatment plan can be completely irradiated onto RUBY system including non-coplanar treatment fields with couch rotation. A compatible detector can be positioned in the System QA

insert using the required detector holder to measure the dose at the center of the phantom. Finally, this measured dose value can be compared with the dose value calculated by the TPS.

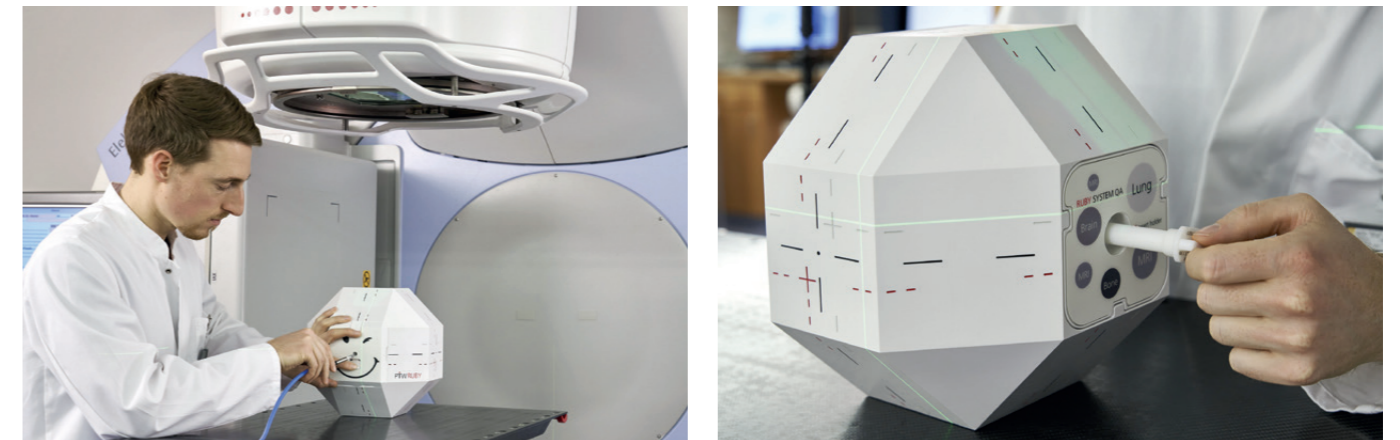

Figure 17: The detector holder corresponding to the detector is screwed into the insert on the back and the detector is inserted into the insert from the front. This method ensures an exact positioning of the detector in the phantom center in relation to the CT markers.

Multiple metastasis applications

The irradiation of multiple metastases with one isocenter is getting increasing clinical relevance. These non-isocentric treatment techniques require additional quality assurance. The System QA MultiMet insert is dedicated to the verification of these irradiation techniques, with or without couch rotation.

The System QA MultiMet insert enables the positioning of three detectors at different positions within the insert marked with CT

markers. The positions have a maximum longitudinal spacing of 10 cm as well as a maximum lateral spacing of 5.5 cm and a maximum vertical spacing of 4.8 cm from each other. Thus, the detector positions simulate the locations of three brain metastases treated simultaneous using a single isocenter. Three bone equivalent cylinders are embedded to provide contrast for positioning using kV imaging systems.

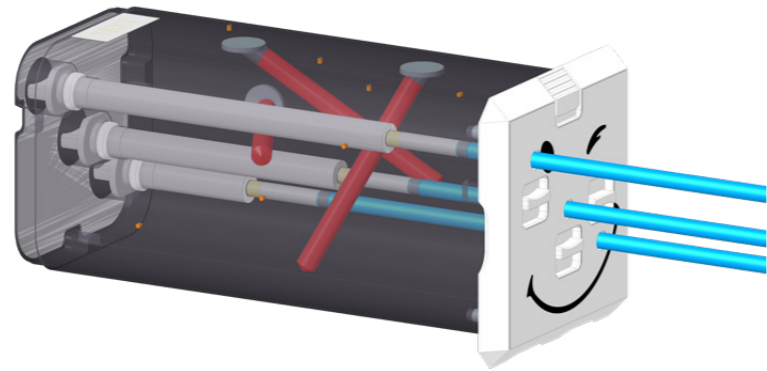

Treatment planning

Target volumes, with sizes corresponding to the clinical standard, can be contoured at the detector positions. The bone structures can be defined as organs of risk (OAR). A single isocenter treat-

ment plan can be optimized for the target volumes by avoiding the cylinder bone structures.

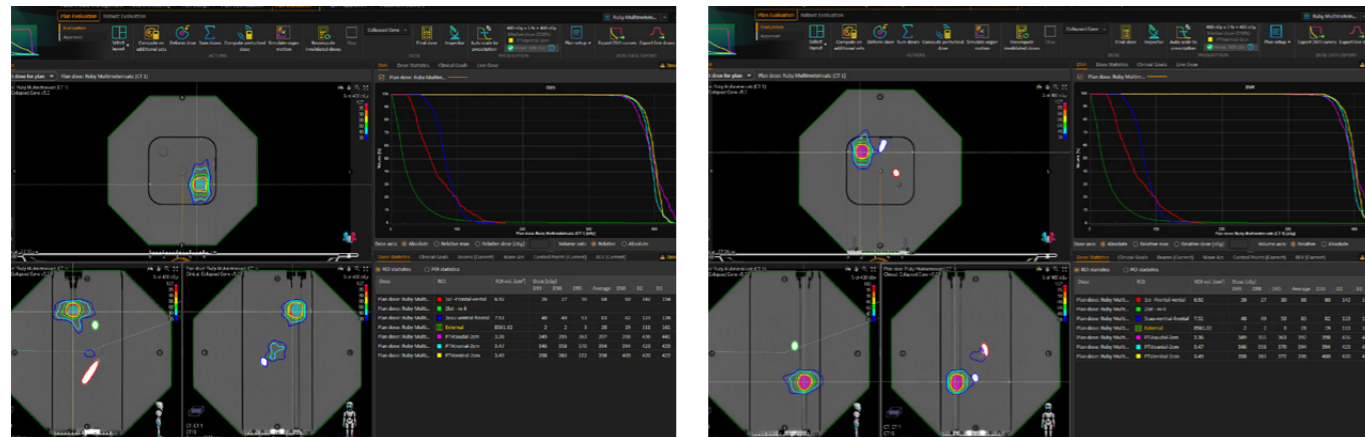

Figure 18: Single isocenter treatment plan irradiating three target volumes. Target volumes are contoured at the detector positions. Isocenter is placed at the center of the phantom.

Patient positioning workflow

The bone structures allow the positioning of the phantom using CBCT or planar kV imaging. Figure 19 illustrates CBCT imaging, while in Figure 20 planar imaging using Exactrac is presented.

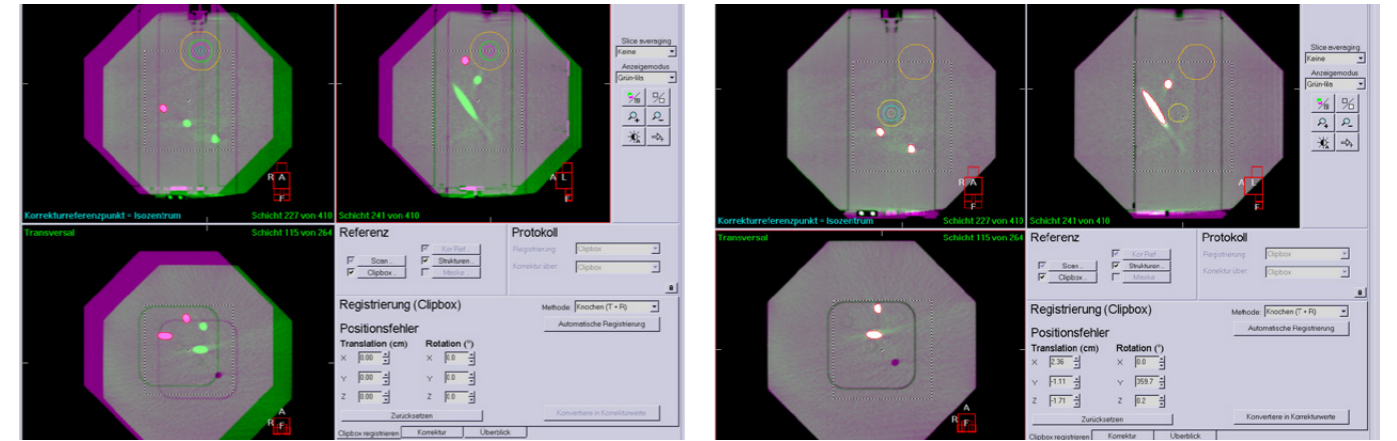

Figure 19: CBCT image registration of the System QA MultiMet insert. Left: Before image registration. Right: After image registration



Figure 20: kV image registration of the System QA MultiMet insert. Left: kV images before image registration. Center: After image registration. Right: RUBY phantom with System QA MultiMet insert and Brainlab frame.

Dose measurement

After positioning the phantom on the couch, detectors can be inserted at the specified detector positions and the dose can be measured. For all positions, detector holders for compatible PTW detectors are available. Either three detectors can be positioned simultaneously within the insert or only one detector is used, while the other two positions are filled with homogeneous plugs.

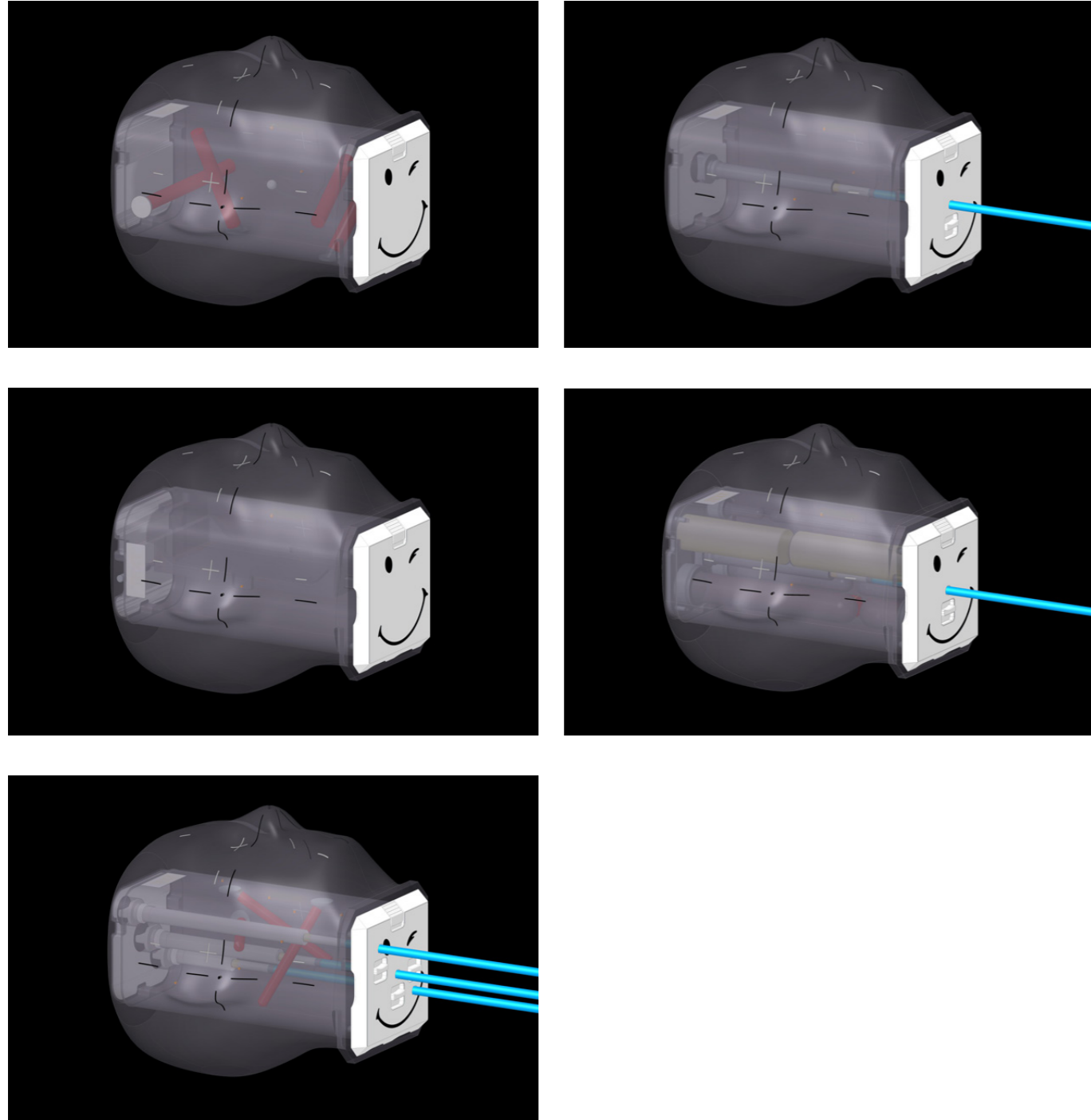

Figure 21: Simultaneous dose measurement in the System QA MultiMet insert using three PinPoint 3D ionization chambers and three UNIDOS Tango systems

RUBY Head phantom

An increasing number of special stereotactic radiations are performed with couch extensions equipped with head shells. Under these settings, the QA equipment must be positioned within the head shell for the quality assurance of these systems. For this

type of application, the RUBY system can be combined with the RUBY head phantom. The RUBY head phantom is compatible with all inserts containing CT markers that indicate the central position of the inserts.



Mask system compatability

The RUBY head phantom has been successfully tested with the Brainlab mask system as well as the Encompass (QFix) mask system (Figure 22).

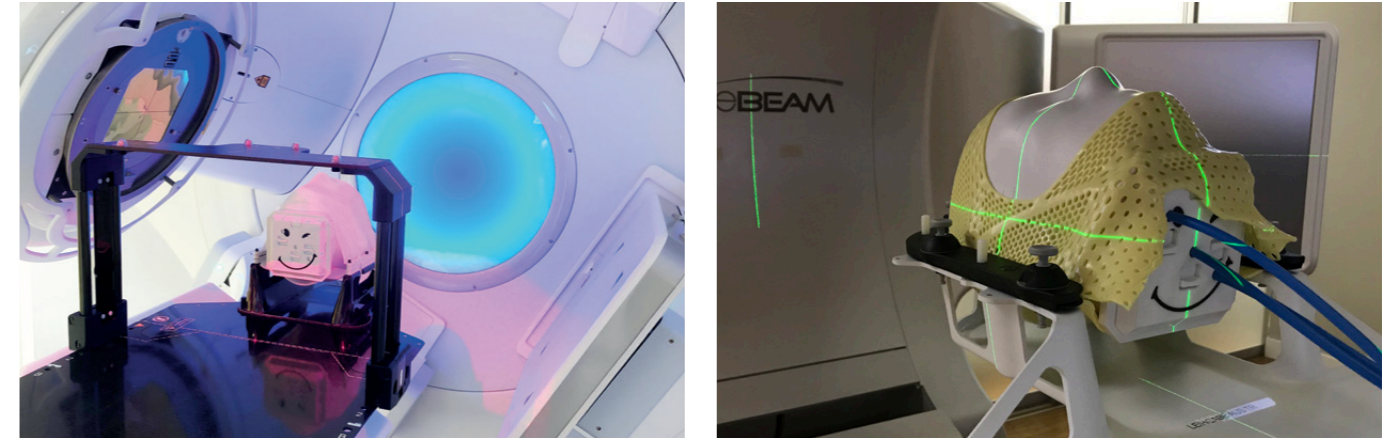

Figure 22: Left: RUBY head phantom and System QA MultiMet insert positioned at an Elekta Hexapod couch with Brainlab mask system and Vision-RT SGRT system. Right: RUBY head phantom with System QA MultiMet insert at a Varian Truebeam linac with Encompass couch extension.

Treatment planning system

The RUBY head phantom with System QA MultiMet insert enables realistic treatment planning of brain metastases. Figure 23 shows single isocenter treatment plans of spherical target volume diameters of 5 mm (left) or 20 mm (right). The bone cylinders were contoured separately and used as organs of risk for plan optimization.

In combination with the RUBY head phantom, RUBY inserts can be used in conjunction with the Varian Hyperarc module. The head phantom can be used to perform the entire Hyperarc workflow. Figure 24 shows a single isocenter multi metastasis treatment plan calculated with the Hyperarc module and the Virtual Dry Run function.

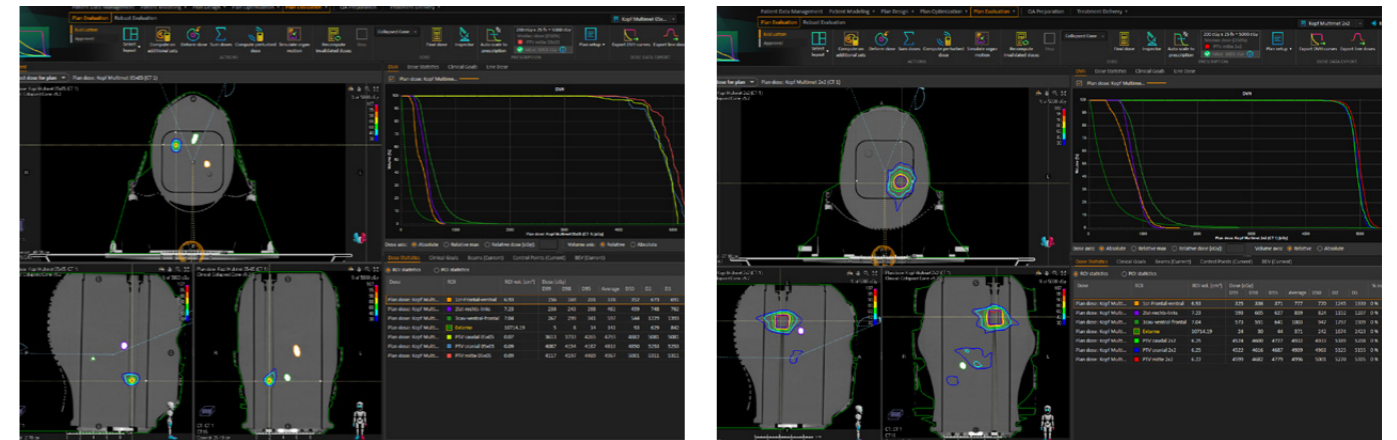

Figure 23: Single isocenter treatment plan optimized on RUBY head phantom and System QA MultiMet insert with Raystation. Left: 5 mm target volume diameter. Right: 20 mm target volume diameter.

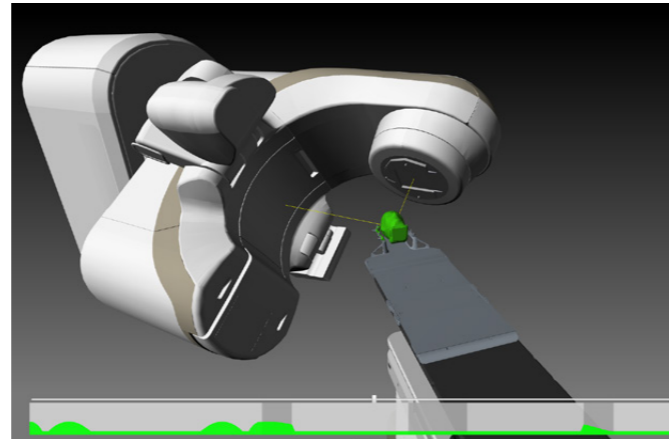
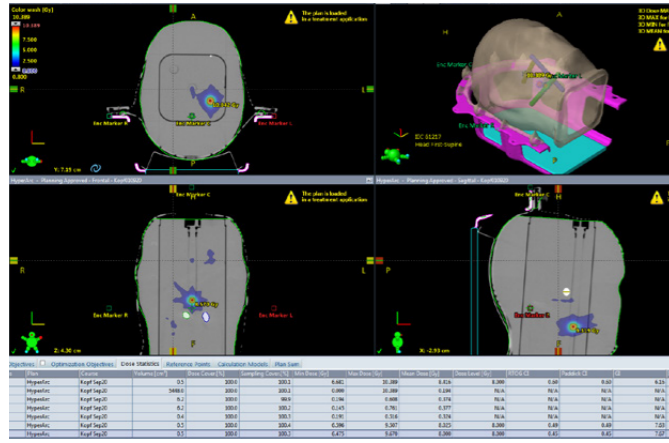

Figure 24: Left: Single isocenter treatment plan optimized on RUBY head phantom and System QA MultiMet insert with Eclipse Hyperarc. Right: Virtual Dry Run option.

Patient positioning workflow

The head phantom is clearly visible in CBCT imaging and can be automatically registered by the evaluated software systems as shown in Figure 25. Even planar kV or kV imaging is possible. Figure 26 shows MV planar imaging performed with a Varian Truebeam system. The mask is clearly visible as well as the

three bone cylinders, which allow image registration with the DRR reference image. Figure 26 also shows kV planar imaging with Brainlab Exactrac system. In addition, the head phantom is detectable with both tested masks in the Vision-RT SGRT system as shown in Figure 27.

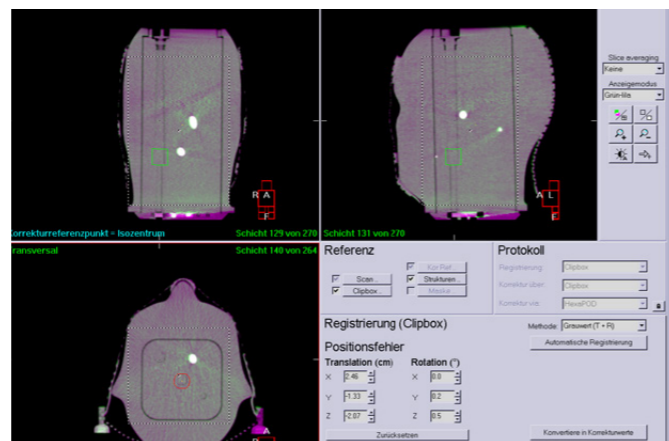
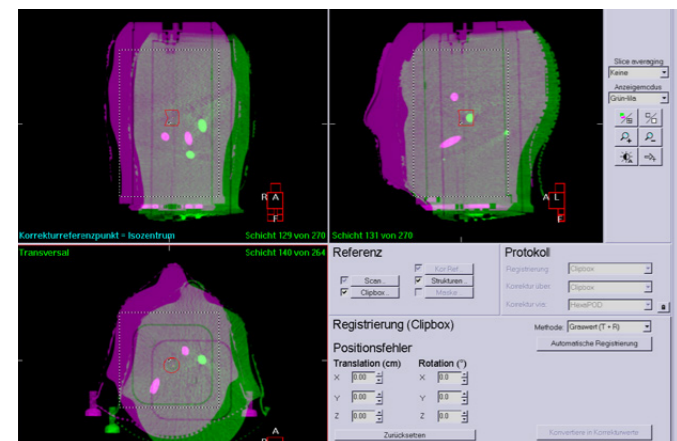
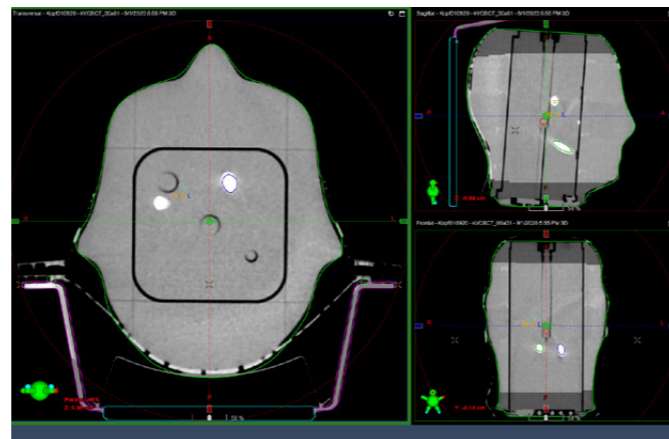
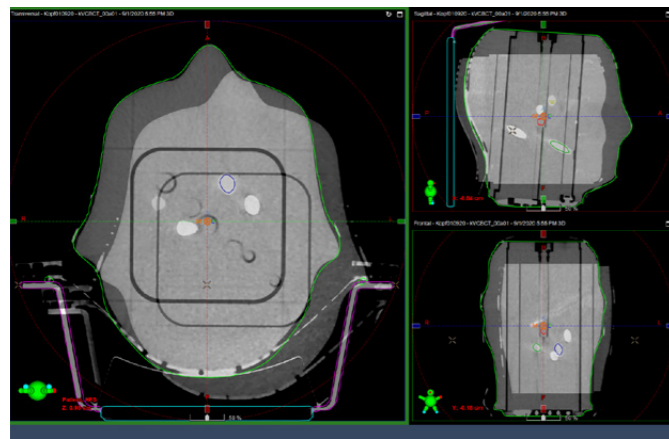

Figure 25: First row: CBCT imaging on Varian Truebeam system of RUBY head phantom with System QA MultiMet insert. Second row: CBCT imaging using Elekta XVI software of RUBY head phantom with System QA MultiMet insert.

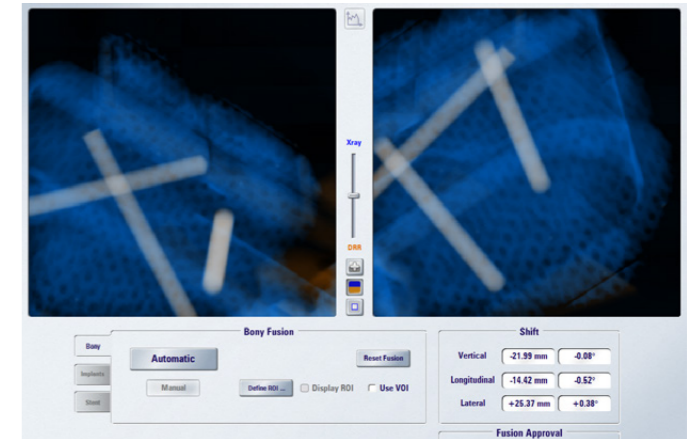
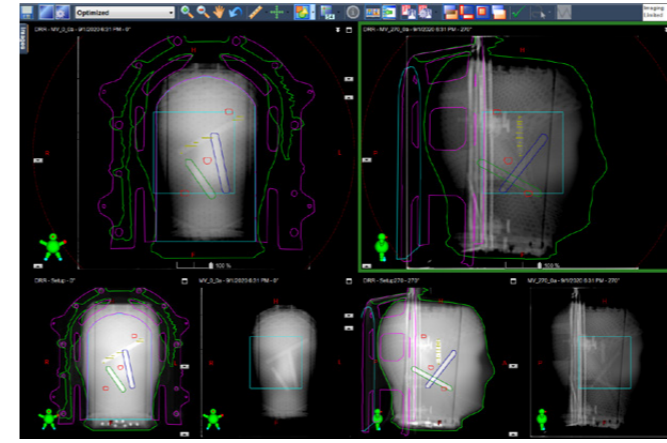

Figure 26: Planar imaging. Left: MV planar imaging on Varian Truebeam system. Right: kV planar imaging with Brainlab Exactrac.

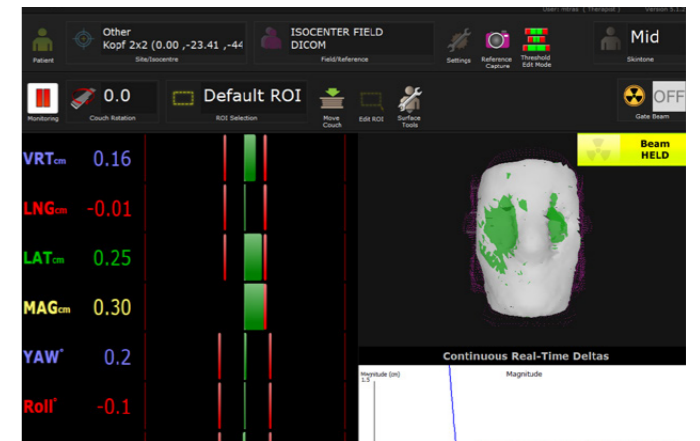
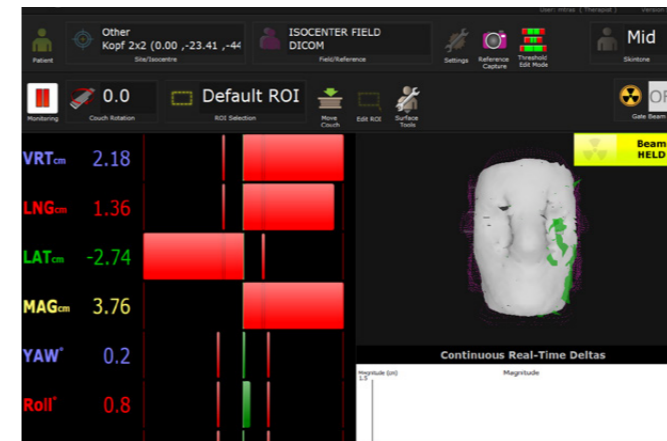

Figure 27: RUBY head phantom monitored by Vision-RT surface guided system. Left: Misaligned Right: Aligned after CBCT imaging



Dosimetry Pioneers since 1922.

PTW is a global market leader for dosimetry and quality control solutions in radiation medicine, serving the needs of medical radiation experts in more than 160 countries worldwide. Starting with the famous Hammer dosimeter in 1922, the German manufacturer is the pioneer in medical radiation measurement, known for its unparalleled quality and precision.

For PTW, making medical radiation safer is both a passion and lifetime commitment. The family-run high-tech company operates the oldest and largest accredited calibration laboratory in the field of ionizing radiation and established THE DOSIMETRY SCHOOL to globally promote the exchange of knowledge in clinical dosimetry.

For more information on RUBY visit
ptwruby.com or contact your local PTW representative:
ptwdosimetry.com/en/contact-us/local-contact

PTW Freiburg GmbH
Loerracher Str. 7
79115 Freiburg · Germany
Phone +49 761 49055-0
info@ptw.de
ptwdosimetry.com

© PTW. All Rights Reserved. Specifications subject to change without prior notice.
All trademarks mentioned in this document are the property of their respective owners.
D968.139.00/01 10-2021

PTW THE
DOSIMETRY
COMPANY